



US008253322B2

(12) **United States Patent**
Lee

(10) **Patent No.:** **US 8,253,322 B2**
(45) **Date of Patent:** **Aug. 28, 2012**

(54) **ORGANIC LIGHT EMITTING DISPLAY
DEVICE INCLUDING LIGHT ABSORPTION
PATTERN UNIT**

(75) Inventor: **Dong-Kyu Lee**, Suwon-si (KR)

(73) Assignee: **Samsung Display Co., Ltd.**, Yongin (KR)

(*) Notice: Subject to any disclaimer, the term of this patent is extended or adjusted under 35 U.S.C. 154(b) by 189 days.

(21) Appl. No.: **12/348,098**

(22) Filed: **Jan. 2, 2009**

(65) **Prior Publication Data**

US 2009/0236976 A1 Sep. 24, 2009

(30) **Foreign Application Priority Data**

Mar. 19, 2008 (KR) 10-2008-0025372

(51) **Int. Cl.**
H01L 51/00 (2006.01)

(52) **U.S. Cl.** **313/504; 313/506**

(58) **Field of Classification Search** **313/504, 313/506, 112, 512**

See application file for complete search history.

(56) **References Cited**

U.S. PATENT DOCUMENTS

5,445,898 A 8/1995 Budzilek et al.
6,781,162 B2* 8/2004 Yamazaki et al. 257/184

7,074,307 B2* 7/2006 Simpson et al. 204/403.04
2003/0146695 A1* 8/2003 Seki 313/506
2003/0222575 A1* 12/2003 Yamazaki et al. 313/504
2005/0073243 A1* 4/2005 Yamazaki et al. 313/498
2005/0073247 A1* 4/2005 Yamazaki et al. 313/503
2005/0195318 A1* 9/2005 Komatsu et al. 348/370

FOREIGN PATENT DOCUMENTS

JP 2000-294380 10/2000
JP 2004-281402 10/2004
JP 2008-10417 1/2008
KR 1996-7000622 1/1996

OTHER PUBLICATIONS

Korean Registration Determination Certificate issued on May 31, 2010, in corresponding Korean Patent Application No. 10-2008-0025372.

Korean Office Action dated Nov. 30, 2009, issued in corresponding Korean patent application.

* cited by examiner

Primary Examiner — Karabi Guharay

(74) *Attorney, Agent, or Firm* — Christie, Parker & Hale, LLP

(57) **ABSTRACT**

An organic light emitting display device includes a substrate, a display unit that is formed on the substrate, and includes a plurality of organic light emitting regions that emit light, a sealing member disposed above the display unit, and one or more light absorption pattern units formed on a plurality of non-light emitting regions of the display unit.

18 Claims, 3 Drawing Sheets

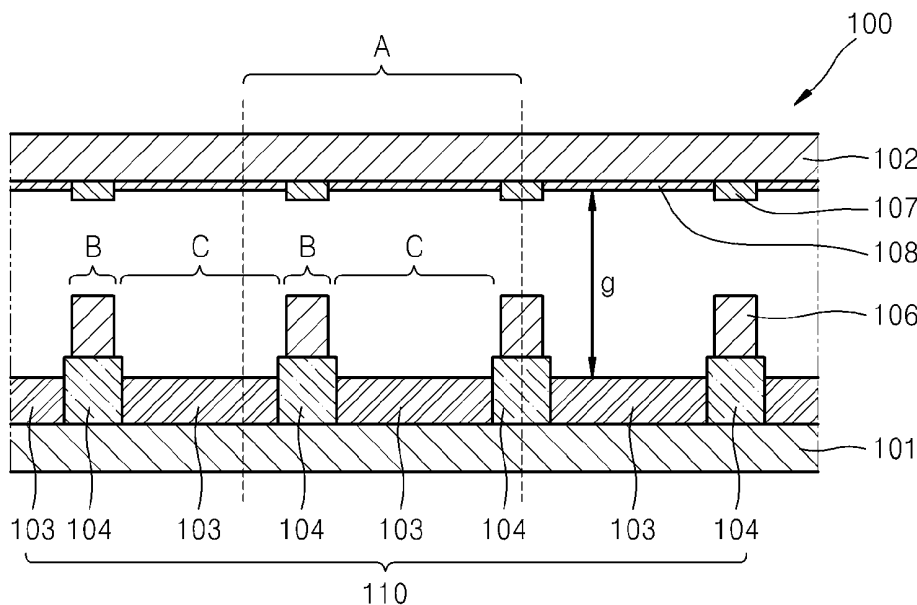

FIG. 1

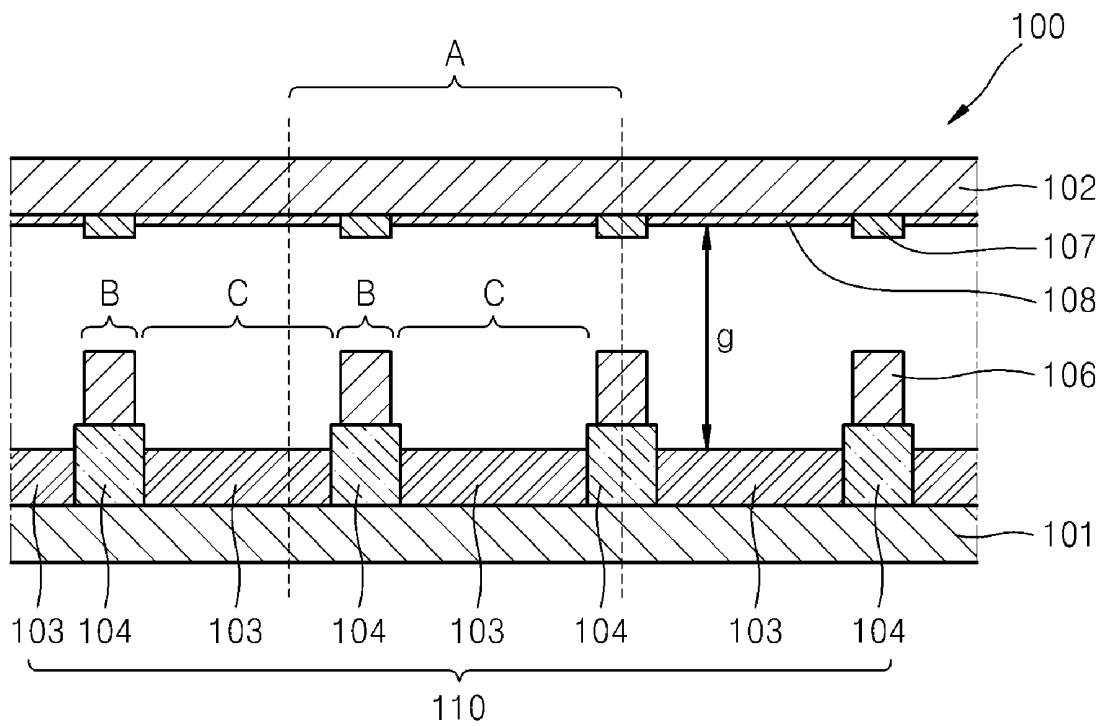
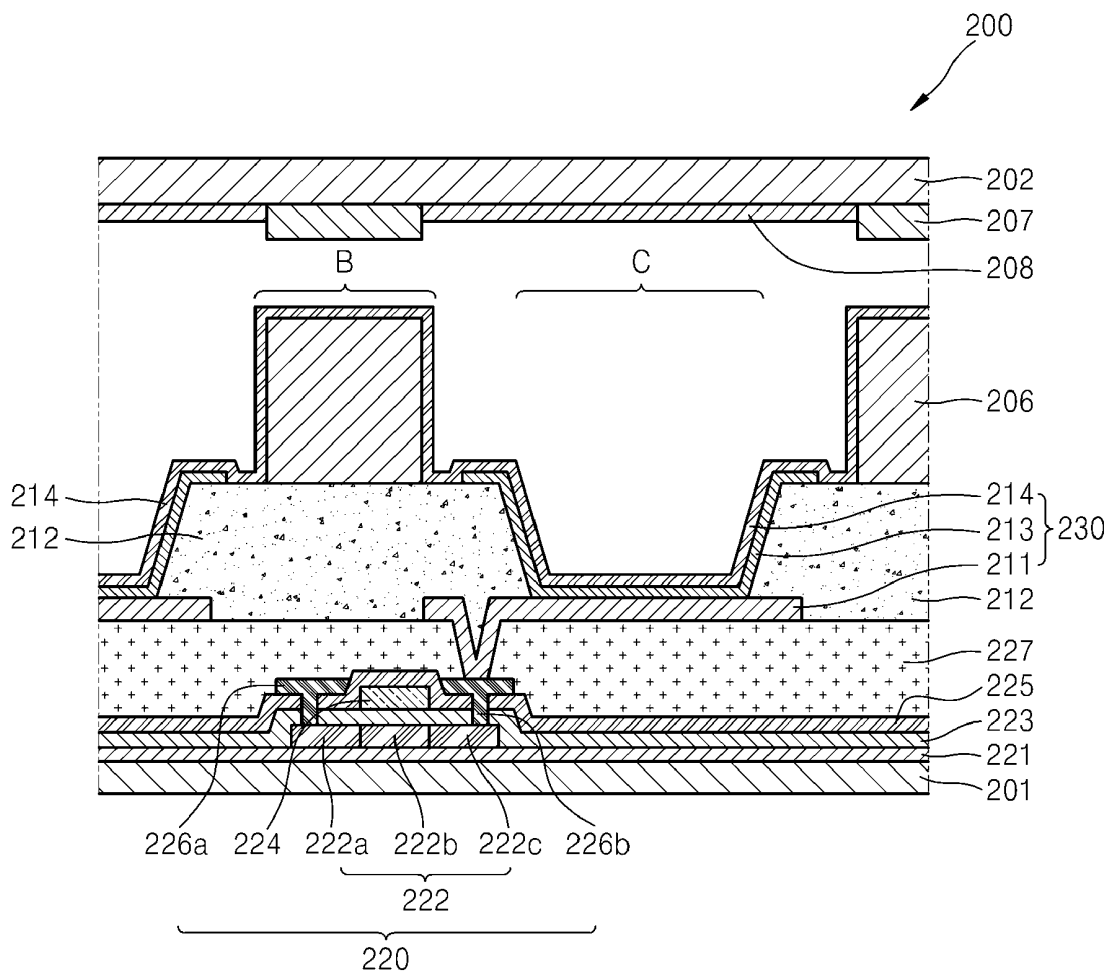

FIG. 3



**ORGANIC LIGHT EMITTING DISPLAY
DEVICE INCLUDING LIGHT ABSORPTION
PATTERN UNIT**

CROSS-REFERENCE TO RELATED
APPLICATION

This application claims the benefit of Korean Application No. 2008-25372, filed Mar. 19, 2008, in the Korean Intellectual Property Office, the disclosure of which is incorporated herein by reference.

BACKGROUND OF THE INVENTION

1. Field of the Invention

Aspects of the present invention relate to an organic light emitting display device, and more particularly, to an organic light emitting display device with improved viewing angles.

2. Description of the Related Art

Organic light emitting display devices are self-emissive display devices that generate light. The light is generated by a re-combination of electrons and holes in an organic emissive layer when a voltage is applied to an organic film containing the organic emission layer. The organic film includes an anode, a cathode, and the organic emissive layer that is interposed between the anode and the cathode. Organic light emitting display devices are expected to be the next generation display devices due to their advantages as compared to those of cathode ray tubes (CRTs) or liquid crystal displays (LCDs). Such advantages include being light weight, being thin in thickness, having wide viewing angles, having short response times, and having a low power consumption rate.

In organic light emitting display devices, an organic light emitting device is disposed in a display region. The organic light emitting device includes a first electrode and a second electrode that face each other, and an emissive layer interposed between the first electrode and the second electrode. Since the organic light emitting device is easily damaged by moisture or oxygen penetrating from the outside, the organic light emitting display device is sealed so that penetration of moisture or oxygen from the outside can be prevented or reduced.

SUMMARY OF THE INVENTION

Aspects of the present invention include an organic light emitting display device with improved viewing angles.

According to an aspect of the present invention, an organic light emitting display device includes: a substrate; a display unit that is formed on the substrate, and comprises a plurality of organic light emitting regions that emit light; a sealing member disposed above the display unit; and one or more a light absorption pattern units formed on a plurality of non-light emitting regions of the display unit.

According to an aspect of the present invention, the light absorption pattern unit may be formed to define each of the organic light emitting regions.

According to an aspect of the present invention, the light absorption pattern unit may reduce light emitted from each of the organic light emitting regions from being mixed with each other.

According to an aspect of the present invention, the organic light emitting display device may further comprise a black matrix formed on a surface of the sealing member to correspond to the non-light emitting region of the display unit.

According to an aspect of the present invention, the organic light emitting display device may further comprise color fil-

ters formed on a surface of the sealing member to correspond to each of the organic light emitting regions.

According to another aspect of the present invention, an organic light emitting display device includes: a substrate; a first electrode formed on the substrate; a pixel defining layer that is formed on the first electrode, and exposes a portion of the first electrode; an intermediate layer comprising an emissive layer, and formed on the exposed portion of the first electrode; a second electrode disposed on the pixel defining layer and the intermediate layer; and a light absorption pattern unit formed on the second electrode to correspond to the pixel defining layer.

According to an aspect of the present invention, the light absorption pattern unit may be formed to define the intermediate layer.

According to an aspect of the present invention, the light absorption pattern unit may reduce light emitted from the intermediate layer from being mixed with each other.

According to an aspect of the present invention, the organic light emitting display device may further comprise a black matrix formed on a surface of the sealing member to correspond to the pixel defining layer.

According to an aspect of the present invention, the organic light emitting display device may further comprise a color filter formed on a surface of the sealing member to correspond to the pixel defining layer.

According to another aspect of the present invention, an organic light emitting display device includes: a substrate; a first electrode formed on the substrate; a pixel defining layer that is formed on the first electrode and exposes a portion of the first electrode; an intermediate layer comprising an emissive layer, and formed on the exposed portion of the first electrode; a light absorption pattern unit formed on the pixel defining layer; and a second electrode formed to cover the intermediate layer and the light absorption pattern layer.

According to an aspect of the present invention, the light absorption pattern unit may be formed to define the intermediate layer.

According to an aspect of the present invention, the light absorption pattern unit may reduce light emitted from the intermediate layer from being mixed with each other.

According to an aspect of the present invention, the organic light emitting display device may further comprise a black matrix formed on a surface of the sealing member to correspond to the pixel defining layer.

According to an aspect of the present invention, the organic light emitting display device may further comprise a color filter formed on a surface of the sealing member to correspond to the pixel defining layer.

According to an aspect of the present invention, an organic light emitting display device includes an organic light emitting device to emit light, the organic light emitting device including an organic light emitting layer to define a light emitting region of the organic light emitting device, and a pixel define layer to define a non-light emitting region of the organic light emitting device; and a sealing member placed over the organic light emitting device and used to form a sealed space between the organic light emitting device and the sealing member, the sealing member including a black matrix to absorb light, the black matrix being formed on a surface of the sealing member at a location that corresponds to the non-light emitting region of the organic light emitting device.

Additional aspects and/or advantages of the invention will be set forth in part in the description which follows and, in part, will be obvious from the description, or may be learned by practice of the invention.

BRIEF DESCRIPTION OF THE DRAWINGS

These and/or other aspects and advantages of the invention will become apparent and more readily appreciated from the following description of the aspects, taken in conjunction with the accompanying drawings of which:

FIG. 1 is a schematic cross-sectional view of an organic light emitting display device according to an aspect of the present invention;

FIG. 2 is an enlarged cross-sectional view of portion A of FIG. 1 according to an aspect of the present invention; and

FIG. 3 is a schematic cross-sectional view of an organic light emitting display device according to another aspect of the present invention.

DETAILED DESCRIPTION OF THE EMBODIMENTS

Reference will now be made in detail to aspects of the present invention, examples of which are illustrated in the accompanying drawings, wherein like reference numerals refer to the like elements throughout. The aspects are described below in order to explain the present invention by referring to the figures.

FIG. 1 is a schematic cross-sectional view of an organic light emitting display device **100** according to an aspect of the present invention. FIG. 2 is an enlarged cross-sectional view of portion A of FIG. 1 according to an aspect of the present invention. Referring to FIG. 1, the organic light emitting display device **100** includes a substrate **101**, a sealing member **102**, a display unit **110**, a plurality of light absorption pattern units **106**, black matrices **107**, and color filters **108**.

The substrate **101** can be formed of a material such as transparent glass, plastic sheet, or silicon, and may be flexible or inflexible, and transparent or opaque. However, aspects of the present invention are not limited thereto, and the substrate **101** may also be formed of a metal plate.

The display unit **110** is formed on the substrate **101**, and may include a plurality of organic light emitting regions **103** that emit light, and a plurality of non-light emitting regions **104** that do not emit light. The organic light emitting region **103** may include an organic light emitting device that is self-emissive, and the non-light emitting region **104** may be a pixel defining layer. The organic light emitting region **103** may include an RGB independent light emitting device (or an individual red, green, or blue light emitting device) that emits red light (R), green light (G), or blue light (B). In addition, the organic light emitting region **103** may include a white organic light emitting device that emits white light (W).

In the case when the organic light emitting display device **100** is an active matrix type, as shown in FIG. 2, the display unit **110** may include a plurality of organic light emitting devices **130**, which are self-emissive, and thin film transistors **120**. The organic light emitting devices **130** and the thin film transistors **120** will be described in detail later with reference to FIG. 2.

The display unit **110** includes a light emitting region C, where the organic light emitting device **130** is formed, and a non-light emitting region B, where the organic light emitting device **130** is not formed. The light absorption pattern unit **106** may be disposed in the non-light emitting region B, as shown in FIG. 1, as will be described later in greater detail with reference to FIG. 2. Aspects of the present invention is not limited to the organic light emitting display device **100** of an active matrix type, but can also be applied to an organic light emitting display device of a passive matrix type, for example, or other types.

The sealing member **102** is disposed on an upper side of the display unit **110** and may be combined with the substrate **101**. As illustrated in FIG. 1, the sealing member **102** may be disposed separately from the display unit **110**, and can be joined with the substrate **101** using an adhesion member or an adhesive (not shown) at peripheries thereof, for example. The sealing member **102** can be a glass substrate, but also various plastic substrates formed of, for example, acrylic, or other polymers.

In the case when the organic light emitting display device **100** is a top emission type device, the sealing member **102** can be formed of an electrical insulating material having high transparency with respect to light generated from the display unit **110**. Examples of the electrical insulating material includes a transparent glass, such as alkali glass and non-alkali glass, transparent ceramics, such as zirconia and quartz, and polymers, such as polyethylene terephthalate, polycarbonate, polyether sulfone, polyvinyl fluoride (PVF), and polyacrylate. The black matrix **107** or the color filters **108** may be formed on a surface of the sealing member **102** to improve light isolation, and to enhance color, respectively.

As shown in FIG. 1, the light absorption pattern unit **106** may be formed on the non-light emitting region **104** of the display unit **110**. The non-light emitting region **104** may include a pixel defining layer **112**, and thus, the light absorption pattern unit **106** may be formed on the pixel defining layer **112**, as will be shown in more detail with reference to FIG. 2. The light absorption pattern unit **106** may be formed on a second electrode **114** corresponding to the pixel defining layer **112**.

The light absorption pattern units **106** may be formed to define each of the organic light emitting regions **103**. That is, one organic light emitting region **103** may be formed between adjacent light absorption pattern units **106**. The light absorption pattern units **106** may reduce or prevent light emitted from each of the organic light emitting regions **103** from being mixed with each other. That is, the light absorption pattern units **106** reduce leakage of light from one organic light emitting region **103** to another organic light emitting region **103**.

In particular, a gap *g* exists between the sealing member **102** and the display unit **110**, which is referred to as a cell gap *g*. In general, the cell gap *g* may be 5 μm or more. Due to the presence of the cell gap *g*, and in the absence of the light absorption pattern units **106**, light emitted from each of the organic light emitting regions **103** can be mixed with each other. If lights emitted from different organic light emitting regions **103** are mixed with each other, viewing angles become small. In aspects of the present invention, the cell gap *g* may be defined from a surface of the organic light emitting region **103** to a surface of the color filters **108**, as shown in FIG. 1, but such is not necessary.

The light absorption pattern units **106** used in aspects of the present invention each has a predetermined height, which may be constant, and are formed on the non-light emitting region **104** to define each of the organic light emitting regions **103**. Thus, the light absorption pattern units **106** can prevent or reduce lights emitted from each of the organic light emitting regions **103** from being mixed with each other. Thus, the light absorption pattern units **106** prevent or mitigate the viewing angles from becoming smaller or reduced.

The height of the light absorption pattern unit **106** may be in a range of 2 to 3 μm , and the light absorption pattern unit **106** may comprise a material having a high light absorption coefficient. For example, the light absorption pattern unit **106** may comprise a polymer organic material having a high light absorption coefficient, such as carbon black.

Since the light absorption pattern unit **106** has a constant height as described above and is formed on the non-light emitting region **104**, a distance between the sealing member **102** and the display unit **110** can be maintained constant. That is, the light absorption pattern unit **106** prevents the sealing member **102** from contacting the display unit **110** or portions thereof. The light absorption pattern unit **106** maintains the constant distance between the sealing member **102** and the display unit **110**, and thus, can prevent or reduce Newton's ring that may occur if the distance between the sealing member **102** and the display unit **110** is not constant. As described above, the light absorption pattern unit **106** has a constant height and is formed on each of the non-light emitting region **104** that defines the organic light emitting regions **103**. Thus, the distance between the sealing member **102** and the display unit **110** is maintained constant, and Newton's ring can be prevented or reduced, accordingly.

The black matrix **107** may be formed on a surface of the sealing member **102** to correspond to each of the non-light emitting regions **104**. As illustrated in FIGS. **1** and **2**, the black matrix **107** may be formed on a bottom surface of the sealing member **102**, which faces the display unit **110**. Alternatively, the black matrix **107** may be formed on a top surface of the sealing member **102**, which is opposite to (or faces away from) the display unit **110**. In either case, the black matrix **107** absorbs light incident from the outside, thus reducing reflection of an external light and resulting in an improvement in light room contrast of the organic light emitting display device **100**. The black matrix **107** may comprise an organic polymer resin having a low light reflectance and/or high light absorption coefficient. In aspects of the present invention, the black matrix **107** may be formed of the polymer organic material of the light absorption pattern **106**, though such is not necessary.

In other aspects of the present invention, the black matrix **107** may be formed on both the bottom and top surfaces of the sealing member **102**. If so, the black matrices **107** on the bottom and top surfaces of the sealing member **102** may be aligned so that the black matrix **107** on the bottom surface and the black matrix **107** on the top surface on corresponding positions of the sealing member. Nevertheless, it is understood that the black matrix **107** on the bottom surface and the black matrix **107** on the top surface need not be so aligned.

The color filters **108** may be formed on a surface of the sealing member **102** to correspond to each of the organic light emitting regions **103**. As illustrated in FIGS. **1** and **2**, the color filters **108** may be formed on the bottom surface of the sealing member **102**, which faces the display unit **110**. Alternatively, the color filters **108** may be formed on the top surface of the sealing member **102**, which is opposite to the display unit **110**. The color filters **108** may include a red filter (R), a green filter (G), and/or a blue filter (B).

When the organic light emitting region **103** is an RGB independent light emitting device, the red filter may be formed on a surface of the sealing member **102** to correspond to the organic light emitting region **103** that emits a red light. In addition, the green filter may be formed on a surface of the sealing member **102** to correspond to the organic light emitting region **103** that emits a green light, and the blue filter may be formed on a surface of the sealing member **102** to correspond to the organic light emitting region **103** that emits a blue light. When the color filters **108** is used in the RGB independent light emitting device, the organic light emitting display device **100** can have improved color purity, thereby resulting in improvement in color reproduction. When the organic light emitting region **103** is a white organic light emitting device, red, green and blue colors can be realized in

the organic light emitting regions **103** by an RGB color filters **108**. For example, the respective red, green and blue colors can be realized in the white organic light emitting regions **103** by a respective red, green, and blue color filters **108**.

FIG. **2** is an enlarged cross-sectional view of portion A of FIG. **1** according to an aspect of the present invention. That is, FIG. **2** shows a specific configuration of the display unit **110**. Referring to FIG. **2**, the thin film transistors **120** are formed on the substrate **101**, and the organic light emitting device **130** is formed on each of the thin film transistors **120**. The organic light emitting devices **130** may each include a first electrode **111** that is electrically connected to the thin film transistors **120**, a second electrode **114** disposed on or over an entire surface of the substrate **101**, and an intermediate layer **113** that is disposed between the first electrode **111** and the second electrode **114** and which includes at least an emissive layer.

The thin film transistors **120** formed on the substrate **101** may each include a gate electrode **124**, a source electrode **126a** and a drain electrode **126b**, a semiconductor layer **122**, a gate insulating layer **123** (or a portion thereof), and an interlayer insulating layer **125** (or a portion thereof). The shape of the thin film transistor **120** is not limited to the shape illustrated in FIG. **2**, and various thin film transistors, such as an organic thin film transistor in which the semiconductor layer **122** is formed of an organic material, or a silicon thin film transistor in which the semiconductor layer **122** is formed of silicon, can be used. If necessary, though not required, a buffer layer **121** formed of silicon oxide (SiO_2), silicon nitride (SiN_x), or silicon oxynitride (SiO_xN_y) can further be formed between the thin film transistor **120** and the substrate **101** so as to prevent or reduce penetration of impurities that may be generated from the substrate **101**, into the semiconductor layer **122**, thus improving characteristics of the organic light emitting display device **100**.

The semiconductor layer **122** is formed on the buffer layer **121**, and may be an amorphous or crystalline silicon film, for example. The semiconductor layer **122** may include a source region **122a**, a drain region **122c**, and a channel region **122b**. Also, the semiconductor layer **122** is buried by the gate insulating layer **123**. The gate electrode **124**, corresponding to the semiconductor layer **122**, and the interlayer insulating layer **125** that buries the gate electrode **124** are disposed on the gate insulating film **123**. Additionally, the source electrode **126a** and the drain electrode **126b** are respectively in contact with the source region **122a** and the drain region **122c** through contact holes formed in the gate insulating layer **123** and the interlayer insulating layer **125**.

The organic light emitting device **130** includes the first electrode **111** and the second electrode **114** that face each other, and the intermediate layer **113** that is interposed between the first electrode **111** and the second electrode **114**. The intermediate layer **113** is formed of an organic material. The intermediate layer **113** includes at least an emissive layer, and can include a plurality of layers, as will be described later.

The first electrode **111** functions as an anode, and the second electrode **114** functions as a cathode. Also, the polarity of the first electrode **111** and the second electrode **114** may be opposite to each other. The first electrode **111** may be a transparent electrode or a reflective electrode. When the first electrode **111** is a transparent electrode, the first electrode **111** may include ITO, IZO, ZnO, or In_2O_3 , for example. When the first electrode **111** is a reflective electrode, the first electrode **111** can include a reflective film formed of Ag, Mg, Al, Pt, Pd, Au, Ni, Nd, Ir, Cr, or a compound of these materials, and a film formed of ITO, IZO, ZnO, or In_2O_3 on the reflective film.

The second electrode **114** may also be a transparent electrode or a reflective electrode. When the second electrode **114**

is a transparent electrode, the second electrode **114** may include a film deposited to face the intermediate layer **113** interposed between the first electrode **111** and the second electrode **114**, and an auxiliary electrode or a bus electrode line formed of a material used to form the transparent electrode on the film. The film of the second electrode **114** may be formed of Li, Ca, LiF/Ca, LiF/Al, Al, Mg, or a compound of these materials, and the auxiliary electrode or a bus electrode line may be ITO, IZO, ZnO, or In₂O₃, for example. On the other hand, when the second electrode **114** is a reflective electrode, the second electrode **114** can be formed by depositing Li, Ca, LiF/Ca, LiF/Al, Al, Mg, or a compound of these materials as the second electrode **114**.

The pixel defining layer **112** covers edges and portions of a top surface of the first electrode **111** that are close to the edges of the first electrode **111**. The pixel defining layer **112** is formed to have a predetermined thickness in portions where the pixel defining layer **112** is not formed over the first electrode **111**. The pixel defining layer **112** defines a light emitting region, and also widens a gap or a distance between the respective edges of the first electrode **111** and the second electrode **114**, thus preventing or reducing an occurrence of an electric field concentration phenomenon at the edges of the first electrode **111**. As a result, the pixel defining layer **112** prevents or reduces the first electrode **111** and the second electrode **114** from developing a short circuit.

Various intermediate layers **113** that include at least an emissive layer can be formed between the first electrode **111** and the second electrode **114**. The intermediate layer **113** may be formed of a small molecular organic material or a polymer organic material.

When the intermediate layer **113** is formed of the small molecular organic material, the intermediate layer **113** may be formed in a single or composite structure including a hole injection layer (HIL), a hole transport layer (HTL), an organic emission layer (EML), an electron transport layer (ETL), or an electron injection layer (EIL). The organic material that can be used to form the intermediate layer **113** includes copper phthalocyanine (CuPc), N,N'-Di(naphthalene-1-yl)-N,N'-diphenylbenzidine (NPB), and tris-8-hydroxyquinoline aluminum (Alq3). The intermediate layer **113** formed of this small molecular organic material may be formed by vacuum deposition using masks.

The intermediate layer **113** formed of the polymer organic material may include an HTL and an EML. The HTL may be formed of poly-(3,4)-ethylene-dihydroxy thiophene (PEDOT), and the emissive layer may be formed of a polymer organic material such as polyphenylene vinylenes (PPVs) and polyfluorenes.

The organic light emitting device **130** is electrically connected to the thin film transistor **120** formed therebelow. In this case, if a planarizing film **127** is formed to cover the thin film transistor **120**, the organic light emitting device **130** is disposed on the planarizing film **127**, and the first electrode **111** of the organic light emitting device **130** is electrically connected to the thin film transistor **120** through a contact hole formed in the planarizing film **127**.

FIG. 3 is a schematic cross-sectional view of an organic light emitting display device **200** according to another aspect of the present invention. The organic light emitting display device **200** illustrated in FIG. 3 has a structure different from that of the organic light emitting display device **100** illustrated in FIG. 2. Specifically, a position of a light absorption pattern unit **206** of the organic light emitting display device **200** is different from a position of the light absorption pattern unit **106** of the organic light emitting display device **100**.

On the other hand, the following of the organic light emitting display device **200** correspond to those of the organic light emitting display device **100**. Namely, a substrate **201**, a buffer layer **221**, a semiconductor layer **222**, a source region **222a**, a drain region **222c**, a channel region **222b**, a gate electrode **224**, a source electrode **226a**, a drain electrode **226b**, a gate insulating layer **223**, an interlayer insulating layer **225**, a planarizing film **227**, a pixel defining layer **212**, an organic light emitting device **230**, a first electrode **211**, an intermediate layer **213**, a black matrix **207**, a color filter **208**, and a sealing member **202** in the organic light emitting display device **200** of FIG. 3 respectively correspond to the substrate **101**, the buffer layer **121**, the semiconductor layer **122**, the source region **122a**, the drain region **122c**, the channel region **122b**, the gate electrode **124**, the source electrode **126a**, the drain electrode **126b**, the gate insulating layer **123**, the interlayer insulating layer **125**, the planarizing film **127**, the pixel defining layer **112**, the organic light emitting device **130**, the first electrode **111**, the intermediate layer **113**, the black matrix **107**, the color filters **108**, and the sealing member **102** in the organic light emitting display device **100** of FIG. 2. Thus, descriptions thereof will be omitted herein.

Referring to FIG. 3, the light absorption pattern unit **206** is formed on the pixel defining layer **212**, and a second electrode **214** may be formed to cover the intermediate layer **213** and the light absorption pattern unit **206**. While the light absorption pattern unit **106** of the organic light emitting display device **100** of FIG. 2 is formed on the second electrode **114** to correspond to the pixel defining layer **112**, however, the light absorption pattern unit **206** of the organic light emitting display device **200** of FIG. 3 is directly formed on the pixel defining layer **212**.

In addition, the second electrode **214** may be formed to cover both the intermediate layer **213** and the light absorption pattern unit **206**. In the case of when the organic light emitting display device **200** is a top emission type, the second electrode **214** is a transparent electrode. Thus, although the second electrode **214** is formed to cover the light absorption pattern unit **206**, the light absorption pattern unit **206** prevents or reduces light emitted from the organic light emitting device **230** from being mixed with each other, thereby resulting in improvement in viewing angles.

In aspects of the present invention, the light emitting region may be referred to as a pixel or a pixel region.

In FIGS. 1-3, the black matrices **107**, **207** are shown as thinner or shorter than the light absorption pattern **106**, **206**, respectively. However, such is not necessary, and in other aspects of the present invention, the black matrices **107**, **207** may be thicker or longer and the light absorption pattern **106**, **206**, may be thinner or shorter. That is, the black matrices **107**, **207** may be formed to almost contact the light absorption pattern **106**, **206** at a midpoint of the gap *g*, or the black matrices **107**, **207** may be formed to almost contact the light absorption pattern **106**, **206** at a point that is closer to a substrate side than the sealing member side of the organic light emitting diode device.

In aspects of the present invention, dimensions of layers and regions may be exaggerated for clarity. It will also be understood that when a layer or element is referred to as being "on" or "over" another layer or substrate, it can be directly on the other layer or substrate, or intervening layers may also be present. Further, it will be understood that when a layer is referred to as being "under" or "below" another layer, it can be directly under, or one or more intervening layers may also be present.

Accordingly, an organic light emitting display device according to aspects of the present invention can have improved viewing angle and prevent or reduce deterioration in color purity.

Although a aspects of the present invention have been shown and described, it would be appreciated by those skilled in the art that changes may be made in the aspects without departing from the principles and spirit of the invention, the scope of which is defined in the claims and their equivalents.

What is claimed is:

1. An organic light emitting display device comprising:
 - a substrate;
 - a display unit formed on the substrate and comprising a plurality of organic light emitting regions and a plurality of non-light emitting regions;
 - a sealing member above the display unit, the sealing member forming a sealed air space between the display unit and the sealing member, the sealed air space including first air spaces directly over the organic light emitting regions and below the sealing member, and second air spaces directly over the non-light emitting regions and below the sealing member; and
 - light absorption pattern units formed on the non-light emitting regions,
 wherein the light absorption pattern units are configured with a height sufficient
 - to prevent the sealing member from contacting the display unit, and
 - to prevent all light from one of the organic light emitting regions from directly entering ones of the first air spaces corresponding to adjacent ones of the organic light emitting regions.
2. The organic light emitting display device of claim 1, wherein the light absorption pattern units are formed of a material having a high light absorption coefficient.
3. The organic light emitting display device of claim 1, wherein the light absorption pattern units are configured to absorb light emitted from the organic light emitting regions toward the sealing member and to reduce mixing of light of different ones of the organic light emitting regions with each other.
4. The organic light emitting display device of claim 1, further comprising black matrices formed on the sealing member to correspond to the non-light emitting regions.
5. The organic light emitting display device of claim 1, further comprising color filters formed on the sealing member to correspond to the organic light emitting regions.
6. The organic light emitting display device of claim 1, wherein the height of the light absorption pattern units is in a range from about 2 to 3 μm .
7. An organic light emitting display device comprising:
 - a substrate;
 - a first electrode formed on the substrate;
 - a sealing member covering the substrate;
 - a display unit formed on the substrate and between the sealing member and the substrate, the display unit comprising a plurality of organic light emitting regions and a plurality of non-light emitting regions, the display unit and the sealing member defining a corresponding plurality of first spaces directly over the plurality of organic light emitting regions and below the sealing member, and a corresponding plurality of second spaces directly over the plurality of non-light emitting regions and below the sealing member, the display unit comprising:
 - a pixel defining layer formed on the first electrode and defining an opening to expose a portion of the first electrode;

- an intermediate layer comprising an emissive layer and formed on the exposed portion of the first electrode;
 - a second electrode formed on the pixel defining layer and the intermediate layer; and
 - a light absorption pattern unit consisting essentially of a polymer organic material and formed on the second electrode to correspond to the pixel defining layer,
- wherein the light absorption pattern unit is between a first one of the organic light emitting regions and a second one of the light emitting regions, and configured with a height sufficient to prevent all light from the first one of the organic light emitting regions from directly entering one of the first spaces corresponding to the second one of the organic light emitting regions.
8. The organic light emitting display device of claim 7, wherein the height of the light absorption pattern unit is in a range from about 2 to 3 μm .
 9. The organic light emitting display device of claim 7, wherein the light absorption pattern unit is configured to absorb light emitted from the intermediate layer, such that mixing of the light with light emitted from another intermediate layer is reduced.
 10. The organic light emitting display device of claim 7, further comprising:
 - a black matrix formed on the sealing member to correspond to the pixel defining layer.
 11. The organic light emitting display device of claim 7, further comprising:
 - a color filter formed on the sealing member to correspond to the intermediate layer.
 12. The organic light emitting display device of claim 7, wherein the light absorption pattern unit is formed of a material having a high light absorption coefficient.
 13. An organic light emitting display device comprising:
 - a substrate;
 - a first electrode formed on the substrate;
 - a sealing member covering the substrate;
 - a display unit formed on the substrate and between the sealing member and the substrate, the display unit comprising a plurality of organic light emitting regions and a plurality of non-light emitting regions, the display unit and the sealing member defining a corresponding plurality of first spaces directly over the plurality of light emitting regions and below the sealing member, and a corresponding plurality of second spaces directly over the plurality of non-light emitting regions and below the sealing member, the display unit comprising:
 - a pixel defining layer formed on the first electrode and defining an opening to expose a portion of the first electrode;
 - an intermediate layer comprising an emissive layer and formed on the exposed portion of the first electrode;
 - a light absorption pattern unit formed on the pixel defining layer, a top surface of the light absorption pattern unit being above a top surface of the intermediate layer; and
 - a second electrode formed on the intermediate layer and the top surface of the light absorption pattern unit,
 wherein the light absorption pattern unit is between a first one of the organic light emitting regions and a second one of the light emitting regions, and configured with a height sufficient to prevent all light from the first one of the organic light emitting regions from directly entering one of the first spaces corresponding to the second one of the organic light emitting regions.

11

14. The organic light emitting display device of claim 13, wherein the height of the light absorption pattern unit is in a range from about 2 to 3 μm .

15. The organic light emitting display device of claim 13, wherein the light absorption pattern unit is configured to absorb light emitted from the intermediate layer, such that mixing of the light with light emitted from another intermediate layer is reduced.

16. The organic light emitting display device of claim 13, further comprising:

12

a black matrix formed on the sealing member to correspond to the pixel defining layer.

17. The organic light emitting display device of claim 13, further comprising:

5 a color filter formed on the sealing member to correspond to the intermediate layer.

18. The organic light emitting display device of claim 13, wherein the light absorption pattern unit is formed of a material having a high light absorption coefficient.

* * * * *

专利名称(译)	有机发光显示装置包括光吸收图案单元		
公开(公告)号	US8253322	公开(公告)日	2012-08-28
申请号	US12/348098	申请日	2009-01-02
[标]申请(专利权)人(译)	三星显示有限公司		
申请(专利权)人(译)	三星移动显示器有限公司.		
当前申请(专利权)人(译)	三星DISPLAY CO., LTD.		
[标]发明人	LEE DONG KYU		
发明人	LEE, DONG-KYU		
IPC分类号	H01L51/00		
CPC分类号	H01L51/5284 H01L51/5237 H01L27/322 H01L27/3246 H01L51/524		
优先权	1020080025372 2008-03-19 KR		
其他公开文献	US20090236976A1		
外部链接	Espacenet USPTO		

摘要(译)

一种有机发光显示装置，包括基板，形成在基板上的显示单元，并且包括发光的多个有机发光区域，设置在显示单元上方的密封构件，以及一个或多个光吸收图案单元形成在显示单元的多个非发光区域上。

